

INSTALLATION INSTRUCTIONS

Side Lite Drywall

It is particularly important that the overlapping of steel vertical and horizontal studs be avoided, since this produces oversized walls. This, in turn, could create significant installation problems when drywall frames are used.

1. Construct the wall with a rough opening height equal to the finished opening height plus $\frac{3}{4}$ " (19 mm) to 1" (25 mm) maximum. A rough opening width is as follows:
 - a. For 2" (51 mm) face frames – opening width plus 2" (54 mm) to 2- $\frac{3}{8}$ " (60 mm).
 - b. For 1- $\frac{3}{4}$ " (38 mm) and 1- $\frac{1}{2}$ " (44 mm) face frames – opening width plus a maximum of 2" (51 mm).
2. If a wrap around (optional) base anchor is used, notch the drywall in that area.
3. Retract the compression bars in the jambs and install one jamb in position on the wall.
4. Insert the frame head under the corner clips of the jamb and raise into position.
5. Insert the corner clips of the remaining jamb into the opposite end of the head and position the jamb on the wall.
6. Insert vertical mullion and horizontal mullions (if supplied as part of kit) under head.
7. Locate a removable frame spacing bar at the base of the centered frame to maintain proper opening width during the installation.
8. Square and plumb the outside jambs. Install the base anchor screws through the countersink holes in the frame face and into the floor plate or secure bottom of frame to stud with base clips.
9. Square and plumb vertical mullion in door opening and fasten to floor.
10. Fasten sill anchors to floor (if supplied as part of kit) and slide sill between mullion and jamb to floor.
11. Square the top of the frame. Tighten the compression bars by turning the screws counterclockwise. Do not over-tighten.)
12. Install four No. 8 x $\frac{1}{2}$ " (13 mm) sheet metal screws at the corners of the head to attach the head to the jambs.

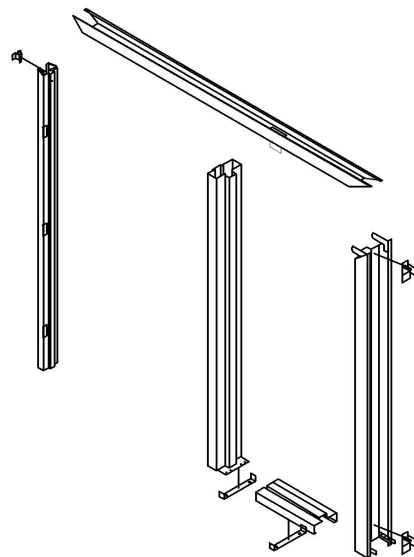
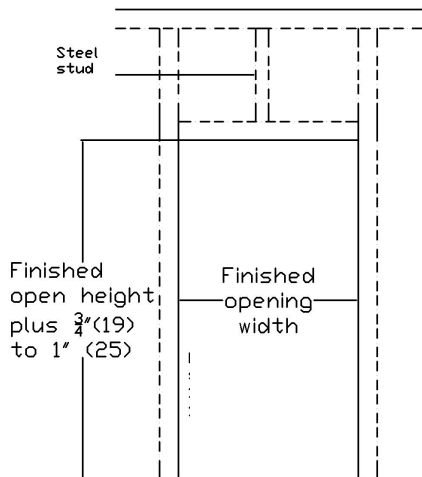

150 Division Drive
Wilmington, NC 28401
www.CustomMetalProductsNC.com
Revised 052907

Phone: 866-893-3338
Fax: 866-963-1355
Info@CustomMetalProducts.bz